



Gibraltar Sports and Leisure Authority
Bayside Sports Centre
Bayside Road
Gibraltar



3rd February 2015

Mr Paul Origo
Development & Planning Commission
Suite 631
Europort
Gibraltar

Dear Paul,

Re: Planning and Building Control Approval Application – Main Hockey Pitch Floodlights.

Please find enclosed the relevant application for the Main Hockey Pitch Floodlights as per your conversation with Michael Caetano (Gib Elec).

I have included all the information/drawings I have at my disposal.

Should you require any further information do not hesitate to contact me.

Yours sincerely,

Reagan Lima
Chief Executive Officer



Secretary
Development and Planning Commission
Suite 631
Europort
Gibraltar

Tel: 350 20075483 Fax: 350 20074086

**Form
1**

APPLICATION FOR PLANNING AND BUILDING CONTROL APPROVAL
Under Sections 17 and 18 of the Town Planning Act, 1999 and Section 45 of the Public Health Act

Please read the guidance notes and complete in block letters. For Outline Planning Applications return 5 copies of this form and of the plans, for Planning/Building Control Approval applications return 8 copies to the above address. The application forms to be at A4 size and 1 set of drawings to be at A1 size with the remainder at A3 size.

<p>1 Applicant's name and address (Not Agent): GIBRALTAR SPORTS AND LEISURE AUTHORITY BAYSIDE SPORTS CENTRE Tel No: 20078409 Fax No: 20042749 E-mail: vicstad@gibtelecom.net/reagan.lima@gibtelecom.net</p>	<p>2 Name and address of Agent: N/A Tel No: Fax No: E-mail:</p>
<p>3 Location of proposed works: MAIN HOCKEY PITCH. Property No: CP/FP:</p>	<p>4 Status of applicant (tick appropriate box): Freeholder <input type="checkbox"/> Leaseholder <input checked="" type="checkbox"/> Tenant <input type="checkbox"/> Other (please specify) <input type="checkbox"/></p>
<p>5 Application Type: (please tick appropriate box): Outline Planning Application <input type="checkbox"/> Planning/Building Control Application <input checked="" type="checkbox"/></p>	<p>6 Previous permission: If this is an application for a permit following the grant of outline planning permission, please state reference number of approved outline planning application: BA..... N/A</p>
<p>7 Description of development: (briefly describe proposals) Installation of Floodlights on Hockey Pitch facility 2N^o on Northern side (runway) - collapsible 2N^o on Southern side (fixed)</p> <p>Tick box if development involves: New build <input checked="" type="checkbox"/> Demolition <input type="checkbox"/> New access to highway <input type="checkbox"/> Change of use <input type="checkbox"/> Alterations/extension <input type="checkbox"/> Altered access to highway <input type="checkbox"/></p>	
<p>8 Estimated cost of works: £ 60,000 (approximately)</p>	<p>9 Owner of building or land (Name and address): (a) Freeholder (b) Leaseholder } HM Government of Gibraltar</p>
<p>10 Use of existing building or land: State the current use of the site: Soccer use - Hockey If vacant state last use: N/A</p>	

11 Density of development (Floor Space Index): Site area:Sq m Aggregate area of floorspace within building:Sq m	12 State total number of parking spaces: Existing: Proposed:																																														
13 Percentage of plot covered by: (a) Existing building% (b) Proposed building%	14 Height of building: State overall height of proposed building(s) in metres :m																																														
15 Environmental Impact Assessment: Does your proposal, require the submission of an Environmental Impact Assessment under the Town Planning (Environmental Impact Assessment) Regulations 2000? YES <input type="checkbox"/> NO <input type="checkbox"/>																																															
16 Felling of trees: Please tick box if development involves the felling of tree(s) and show species and location on plan. <input type="checkbox"/>	17 Drainage: Method of surface & foul water drainage (tick box) New <input type="checkbox"/> Existing <input checked="" type="checkbox"/>																																														
18 Floorspace <table border="1" style="width:100%; border-collapse: collapse; margin-top: 5px;"> <thead> <tr> <th style="width:30%;">Use</th> <th style="width:20%;">Existing sq m</th> <th style="width:20%;">Proposed sq m</th> <th style="width:30%;">Total sq m</th> </tr> </thead> <tbody> <tr><td>Residential</td><td></td><td></td><td></td></tr> <tr><td>Industrial</td><td></td><td></td><td></td></tr> <tr><td>Office</td><td></td><td></td><td></td></tr> <tr><td>Shop</td><td></td><td></td><td></td></tr> <tr><td>Storage/distribution</td><td></td><td></td><td></td></tr> <tr><td>Other (please specify)</td><td></td><td></td><td></td></tr> <tr><td>Total</td><td></td><td></td><td></td></tr> </tbody> </table>		Use	Existing sq m	Proposed sq m	Total sq m	Residential				Industrial				Office				Shop				Storage/distribution				Other (please specify)				Total																	
Use	Existing sq m	Proposed sq m	Total sq m																																												
Residential																																															
Industrial																																															
Office																																															
Shop																																															
Storage/distribution																																															
Other (please specify)																																															
Total																																															
19 Residential type: <table border="1" style="width:100%; border-collapse: collapse; margin-top: 5px;"> <thead> <tr> <th rowspan="2" style="width:30%;">Housing Type</th> <th colspan="2" style="width:20%;">No of units</th> <th rowspan="2" style="width:20%;">Type of units</th> <th colspan="2" style="width:20%;">No of units</th> </tr> <tr> <th style="width:10%;">Existing</th> <th style="width:10%;">Proposed</th> <th style="width:10%;">Existing</th> <th style="width:10%;">Proposed</th> </tr> </thead> <tbody> <tr><td>Detached</td><td></td><td></td><td>1 bedroom</td><td></td><td></td></tr> <tr><td>Semi-detached</td><td></td><td></td><td>2 bedroom</td><td></td><td></td></tr> <tr><td>Terraced</td><td></td><td></td><td>3 bedroom</td><td></td><td></td></tr> <tr><td>Apartments</td><td></td><td></td><td>4 bedroom</td><td></td><td></td></tr> <tr><td></td><td></td><td></td><td>Others</td><td></td><td></td></tr> <tr><td>Total</td><td></td><td></td><td>Total</td><td></td><td></td></tr> </tbody> </table>		Housing Type	No of units		Type of units	No of units		Existing	Proposed	Existing	Proposed	Detached			1 bedroom			Semi-detached			2 bedroom			Terraced			3 bedroom			Apartments			4 bedroom						Others			Total			Total		
Housing Type	No of units		Type of units	No of units																																											
	Existing	Proposed		Existing	Proposed																																										
Detached			1 bedroom																																												
Semi-detached			2 bedroom																																												
Terraced			3 bedroom																																												
Apartments			4 bedroom																																												
			Others																																												
Total			Total																																												

20 **Ownership details (see guidance notes)**

We need to know who owns the application site. If you do not own the site or if you only own part of it, we need to know the name(s) of the owner(s). We also need to be sure that any other owner(s) knows that you have made an application. Please read the attached guidance notes if in doubt.

If you are the sole owner of the whole site Certificate A will apply. Please tick the appropriate box below:

CERTIFICATE A

I certify that at the beginning of the period 21 days ending with the date of this application, nobody, except the applicant, was the owner(s) of any part of the land to which this application relates.

CERTIFICATE B

I certify that the applicant (or his agent) has given the requisite notice (Form S21A attached) to everyone else who, at the beginning of the period 21 days ending with the date of this application, was the owner of any part of the land to which the application relates, as listed below:

Owner's name	Address at which notice was served	Date on which notice was served

Continue on a separate sheet if necessary

21 **Public Participation**

Some types of development are subject to public participation requirements under Section 19 of the Town Planning Act (referred to as "Section 19 developments").

Some common Section 19 developments include :construction of buildings more than 4m in height, extensions of one or more additional storeys where the height would exceed 4m, swimming pools, use of land as bar/restaurant (including fast food restaurants). For the complete list seek advice from the Town Planning Division or refer to the Town Planning (General Procedures) Regulations, 2001, that can be viewed at www.gibraltarlaws.gov.gi

If Section 19 applies you must:

- Place a notice (use form S19 attached) on site and this must remain for at least 14 days. On completion of the 14 days, complete and submit your application.
- Place a notice (use form S19 attached) in the Gibraltar Gazette, a daily and weekly newspaper. Copies of each of the publications in which the notices are published must be submitted as soon as possible after their publication.

Tick the box if the proposal is a Section 19 development.

22 **Drawings**

List all drawings, plans and other documents included with the application.

NB Location and site plan **MUST** be included.

ROOFING MANUAL - HYDRAULIC MATS / MAT ASSEMBLY AND INSTALLATION.
MAT DESIGN DIAGRAMS / FOUNDATION PHOTOGRAPH / LIGHTING SITE PLAN

I/we hereby apply for permission to carry out the development described in this application and accompanying plan(s) and documents. I understand that an initial fee is payable on acknowledgement with a further fee payable following the first inspection following the grant of Building Control approval.

Signed  Date

Guidance Notes

When do I use this form?

This form is only to be used for the following types of application:

Outline Planning Application – prior to submitting the full details required in an application for a Planning Permit, a person may submit an application for Outline Planning Permission (Section 18, Town Planning Act). Outline Planning Permission, if granted will approve the principle of the proposed development subject to certain conditions. Granting Outline Planning Permission does not authorise the commencement of works on site. Following the outline planning stage the applicant will then need to submit a detailed application for a Planning Permit and Building Control approval.

Planning/Building Control Application – This is a joint application for both a Planning Permit (Section 17, Town Planning Act) and for Building Control Approval (Section 45, Public Health Act). A Planning Permit confirms the approval of all planning matters relevant to a development, and may be issued subject to certain specified conditions. Building Control Approval confirms compliance with the Building Regulations and may also be issued subject to conditions.

Do not use this form for any of the following types of application:

- Application for Demolition - use Form 2;
- Application for Advertisement consent - use Form 3;
- Application for Consent to cut/top protected tree - use Form 4.

Forms 2, 3 and 4 are available from the Town Planning/Building Control Division.

How many copies of the application must be submitted?

Outline Planning Application - submit 5 copies of the application form and plans together with any other documentation. One set of plans to be at full scale A1 size and the remainder at A3 size.

Planning/Building Control approval - submit 8 copies of plans and documentation. One set of plans to be at full scale A1 size and the remainder at A3 size.

In both cases, the reduced A3 sets must be legible otherwise larger version of the drawings are to be included.

What Plans and drawings need to be submitted?

- Location plan to a scale 1: 1250 approx - to show the exact location of the site.
- Site Plan to a scale 1:200 approx - to show clearly the boundaries of the site and its relationship with adjacent properties and roads and must include a North arrow. The site boundary should be shown in RED and adjoining land owned or controlled by applicant in BLUE.
- Block Plans, elevations, floor plans, roof plans and sections are to be shown to an appropriate scale (1:50 or 1:100) and must show the layout of the site, the existing building(s) and all proposed changes.
- Other - It is helpful for artists impressions of the proposals to be included. Photographs of the building/land as existing and photographic montages showing the superimposed proposals would be helpful. Larger developments may require a scaled model showing proposals in relation to the surrounding area.
- Design Statement - For major proposals the statement should clearly show the thought process that has led to the submitted design.
- All plans should be clearly annotated.
- All plans and documentation must be in the English language.

Do I need to notify anyone else of my application?

Unless you are the sole "owner" you must serve notice on all other "owners" of the site. A notice for this purpose is included in this application form (Form S21A). Special procedures apply where you have not been able to identify all the owners of the land in question. You should contact the Town Planning Division for further advice. "Owners" include Freeholders, leaseholders and tenants of any part of the application site.

Do I need to pay a fee?

Yes. The amount will be set out in the acknowledgement letter that will be sent to you. Fees should be paid promptly to avoid delays to consideration of the application.

Use this form to notify other 'owners' about your application.

**TOWN PLANNING ACT
NOTICE UNDER SECTION 21 OF AN APPLICATION FOR PLANNING PERMISSION**

Proposed development at (a)..... I/we give
notice that (b)..... is applying to the Development
& Planning Commission for planning permission to (c).....
.....
.....

Any owner* of the land who wishes to make representations about this application should write to the Development and Planning Commission at Suite 631 Europort within 21 days of the date of this notice. Any representations must include a statement confirming that the applicant has been provided with a copy of the representations and the date this was done.

Signed
**On behalf of
Date

*"owner" in relation to any land, means a person who is for the time being the owner in respect of the fee simple thereof or is entitled to a tenancy thereof.

**delete where appropriate.

Insert:

- (a) Address or location of the proposed development.
- (b) Applicant's name.
- (c) Description of the proposed development

This form has a dual purpose - it is to be used as:

- a. A site notice, and
- b. The notice to be published in the press.

TOWN PLANNING ACT

NOTICE UNDER SECTION 19(3) * (To be published in the Gazette and in local newspapers)

NOTICE UNDER SECTION 19(4) * (To be displayed on site)

Proposed development at (a)..... I/we give notice that (b)..... is applying to the Development & Planning Commission for planning permission to (c)

.....

.....

.....

Members of the public may inspect copies of :

- The application
- The plans
- Other documents submitted with it

at the offices of the Secretary of the Development and Planning Commission during working hours until (d).....or the date 21 days from the date this notice was published/erected on site*, whichever is the later.

Anyone who wishes to make representations about this application should write to the Development and Planning Commission at Suite 631 Europort by the date given above or the date 21 days from the date this notice was published/erected on site*, whichever is the later.

Signed

**On behalf of

Date

*Delete as appropriate

- (a) Address or location of the proposed development.
- (b) Applicant's name.
- (c) Description of the proposed development, including the relevant class designated in regulation 15 of the Town Planning (General Procedures) Regulations 2001.
- (d) Date giving a period of not less than 21 days, beginning with the date when the notice is published or first displayed on site (as the case may be).

*Only use this form if you answered, "YES" to question 21 on the application form.
This form certifies that a site notice was erected.*

**TOWN PLANNING ACT 1999
CERTIFICATE UNDER SECTION 19 (3)**

Please tick the appropriate box.

CERTIFICATE A

I certify that I/the applicant* posted the notice (form S19 attached) required by Section 19 (4) of the Act on the land which is the subject of the application. This notice was left in position for at least 14 days in a period of not more than one month immediately preceding the making of the application.

OR

CERTIFICATE B

I certify that I have/the applicant has* been unable to post the notice required by Section 19 (4) of the Act on the land which is the subject of the application because I have/the applicant has* no rights of access or other rights in respect of the land as would enable me/the applicant* to do so.
I have/the applicant has* taken the following steps to acquire those rights, but have/has* been unsuccessful:

.....
.....

OR

CERTIFICATE C

I certify that I/the applicant* posted the notice required by Section 19 (4) of the Act on the land which is the subject of the application. It was however, left in position for less than 14 days in a period of not more than one month immediately preceding the making of the application. This happened because it was removed/obscured/defaced* before the 14 days had passed during the period of one month mentioned above. This was not my/the applicant's fault or intent.
I/the applicant* took the following steps to protect and replace the notice:

.....
.....

Signed
*On behalf of
Date

*Delete as appropriate.

MAST ASSEMBLY AND INSTALLATION

MAST TYPE: RAISE AND LOWER HYDRAULIC - GRANDELUME.

WE STRONGLY RECOMMEND THAT THESE INSTRUCTIONS ARE READ CAREFULLY BEFORE ATTEMPTING TO ASSEMBLE AND INSTALL THIS EQUIPMENT.

REFERENCE SHOULD ALSO BE MADE TO THE APPROPRIATE COUNTERBALANCE OPERATING INSTRUCTIONS WHICH ARE SUPPLIED WITH THE UNIT.

GENERAL

These masts have a wide variety of uses including industrial, railway, airport and sports lighting from 12 to 50m, although other applications and heights below 12m do occur. The foundation bolts should be cast in to the concrete foundation 3 to 4 weeks prior to erection of the mast to allow time to cure. Foundation block sizes for a variety of ground conditions can be supplied on request.

Each mast is supplied in kit form for on site assembly. Masts are constructed from steel to EN10025 grade S275 or S355, pressed to form a series of tapering polygonal shaft sections which are assembled with the square R & L base. The shafts are slotted together and require no on site welding or bolting. The masts and foundation bolts are finished galvanised with small fasteners from stainless steel.

Because these masts are designed for specific applications it is essential that reference is made to the engineering drawings during assembly. These will give details of design overlaps although these will obviously vary due to manufacturing tolerances. The **minimum permissible overlap** can be determined from Fig. 1.

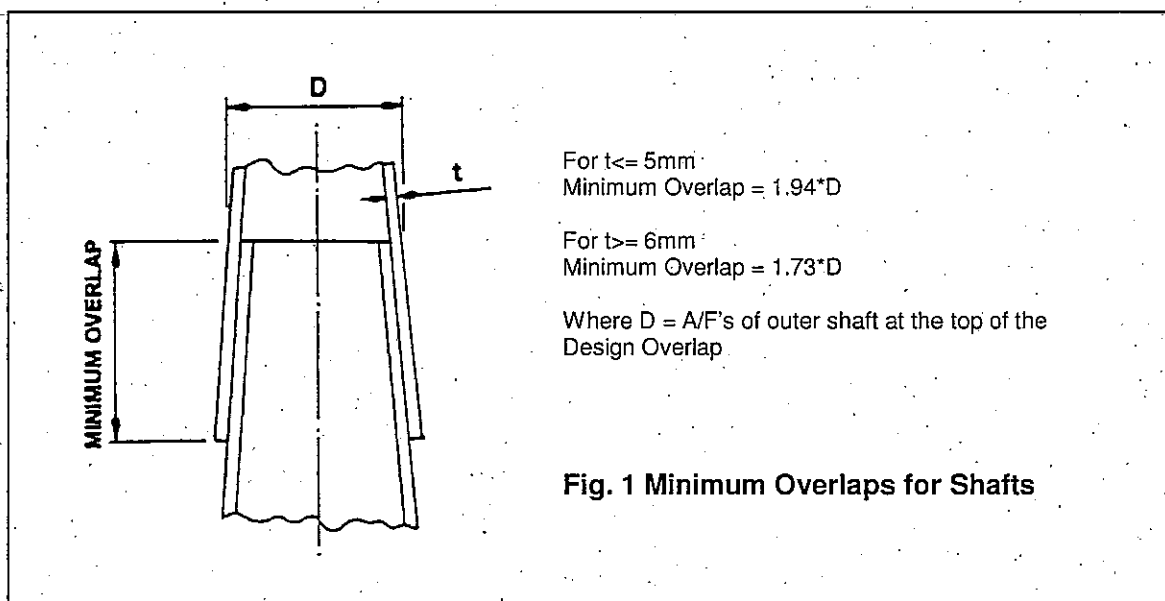

EQUIPMENT REQUIRED. (Not Abacus supply)

- i) 1 no. 3.0 tonne Tirfor c/w wire ropes.
- ii) Various wire ropes, soft slings and shackles
- iii) Supply of liquid soap
- iv) Ø30 steel bar or steel beam with attachment points for 'D' shackles
- v) Supply of timber supports and packing
- vi) Mobile crane to lift mast and headframe, typically 5 tonne
- vii) Torque multiplier and wrench

MAST ASSEMBLY & INSTALLATION

Reference should be made to the illustrations

For export orders the masts will be containerised. If the smaller shafts are fitted inside larger ones, they will need to be carefully unpacked on site to avoid damaging the galvanised finish.

1. The holding down bolts are each fitted with two nuts and washers. The upper nuts and washers and template should be removed. The threads should be examined for any damage and rectified using a die nut if necessary. The nuts should be set in level plane using a steel bar and spirit level across each opposing pair of nuts. Check, referring to the counterbalance operating instructions, that the base section is fully closed and locked. Using a crane lift the column base and place over the foundation bolts and on to the lower set of nuts, ensuring the direction of lowering is as required and that the mast will clear any obstructions.
2. Fit the retaining washers and nuts to the bolts and roughly 'plumb up' the mast (levelling may be easier if only 4 levelling nuts are initially used). Referring to the appropriate operating instructions fit the counterbalance unit and lower the mast base to the horizontal.
3. Before assembly lay the shaft sections end to end on the ground and ensure by sighting from one end that the shafts are straight. Check the overlap area for any damage, excess zinc or weld which may impede fitting of the shafts together and rectify if necessary. It may be necessary to rotate one or all of the sections to achieve the best alignment. Care should be taken to ensure that seam welds on adjoining shafts are not in line.
4. Mark the minimum overlap position on the stub shaft of the mast using the method described in Fig 1. With the base section lowered, pick up, locate and slide home as far as possible the larger shaft sections. Ensure the flats do not rotate relative to each other since a shaft wedged with a corner to a flat will be very difficult to separate. Refer to Fig. 2 for details.

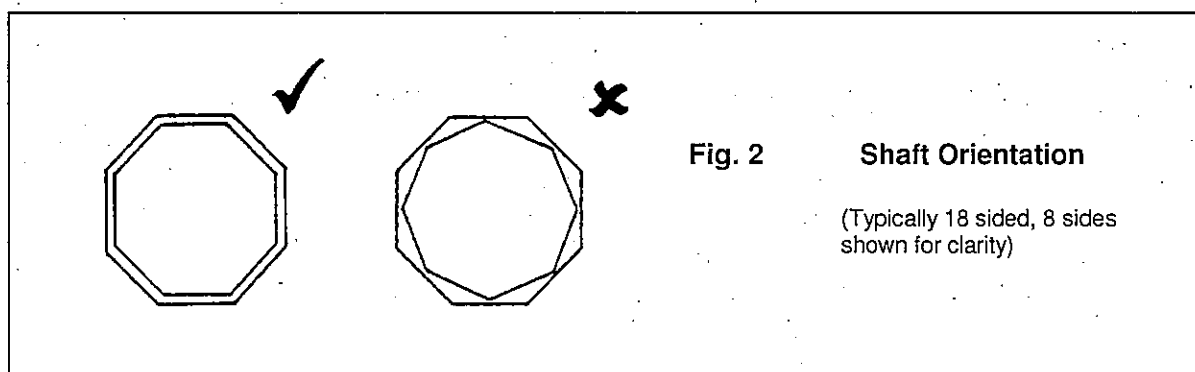

MAST ASSEMBLY & INSTALLATION

5 - 6. The minimum overlap distance must be covered and in most cases exceeded. To achieve this it may be necessary to mechanically pull the shafts together.

For the smaller shafts this may be achieved by knocking the shaft with a hammer, ensuring that a wooden block is placed over the end of the shaft which is to be hit. Smearing liquid soap over the end of each inner shaft before assembly may also help.

For the larger shaft sections, which require assembly by mechanical means it will be necessary to use a Tirfor with a pulling capacity of 3000Kg. Position the Tirfor within the side door of the mast base and attach it via a wire rope and a steel bar to the open base of the mast. Feed the Tirfor wire down the length of the two shafts being assembled and connect it to an attachment plate or bar as illustrated. Protect the shaft edges from deformation using timber packers. The Tirfor wire can then be tensioned and the shaft pulled into position whilst at the same time agitating the shaft up and down. As sliding takes place periodically sight down the assembly to check for straightness. Ensure the minimum overlap has been achieved and remove the attachment plate in readiness for pulling the next shaft into position. Remove any surplus soap from the base section. Repeat the procedure for all remaining shafts. Remove the equipment before attempting to operate the mast.

7. Fit the floodlight mounting bracket to the top shaft section and secure with the screws provided. It should be noted that the power supply cable can be installed during assembly or, if preferred, after assembly is completed, but prior to fixing the floodlighting bracket. All the electrical work should now be carried out.

8 - 9. Follow the appropriate counterbalance operating instructions and raise the mast into its vertical position and dock the lid into the base castellations. Remove and store the counterbalance unit.

After completion of assembly and with the mast raised, recheck for vertical alignment. Use the lower set of nuts to accurately 'plumb up' the column. It should be noted that the base sides are parallel, whereas the shafts are tapered. Once satisfactory all bolts should be tightened to the required torque setting.

If the gap below the flange is to be grouted it is essential that adequate provision is made for ventilation and drainage of any water collecting inside the base.

The mast can then be commissioned.

'Plumbing up' in warm weather or climates. To minimise the effect of the sun on one side of the mast, which can cause considerable temporary curvature of the mast it is recommended that the 'plumbing up' be carried out very early or late in the day.

TORQUE SETTINGS FOR BOLTS

Bolt Size (mm)	Torque Setting (Nm)	
	Grade 4.6	Grade 8.8
M20	50	250
M24	160	425
M30	310	850
M36	550	1450
M42	875	2350
M48	1300	3500

FOR FURTHER ADVICE CONTACT THE ABACUS TECHNICAL DEPARTMENT

ASSEMBLY AND INSTALLATION INSTRUCTIONS FOR GRANDELUME MAST
(SINGLE RAM COUNTERBALANCE SHOWN FOR CLARITY - PROCEDURES ARE THE SAME FOR TWIN UNITS)

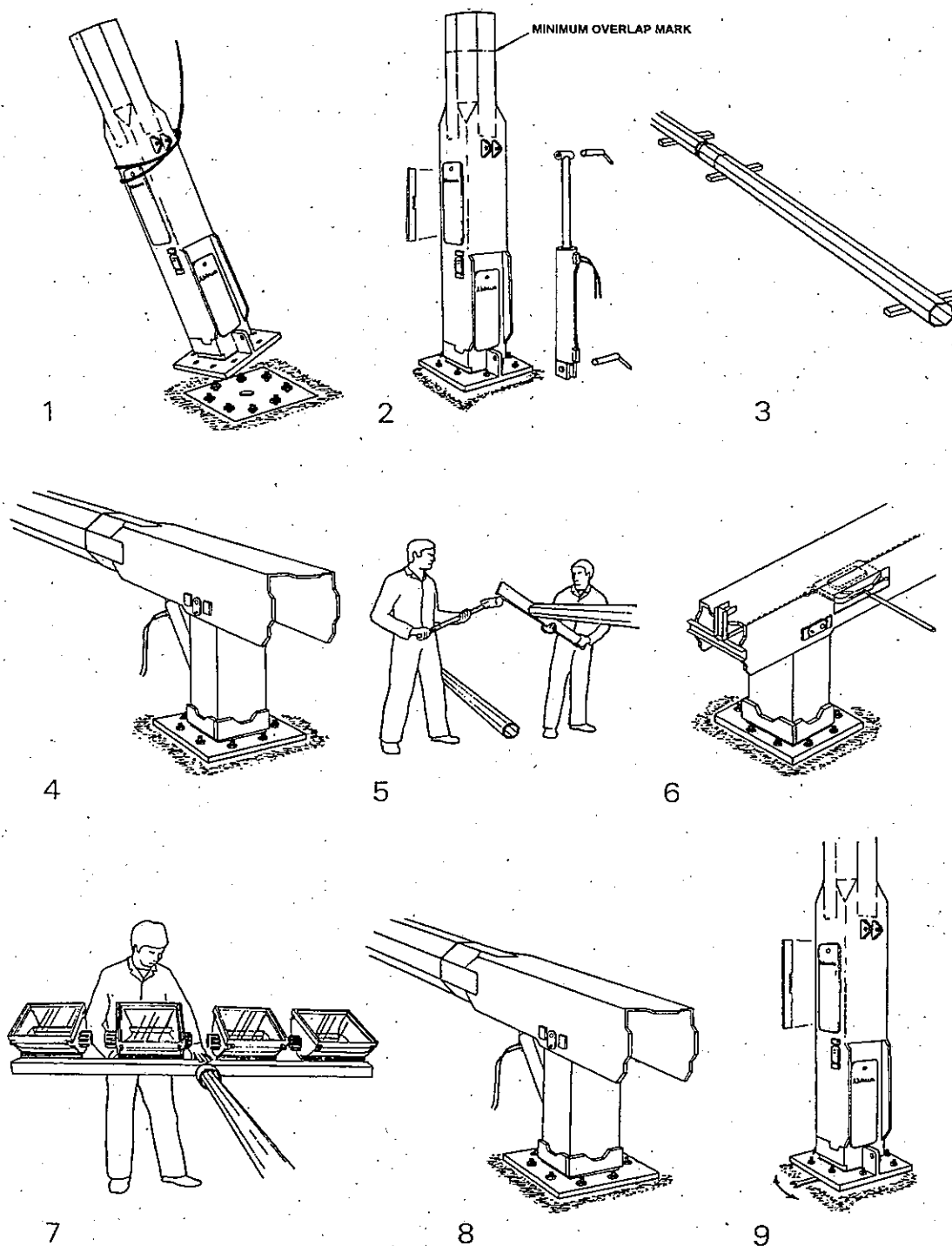

MAST ROUTINE MAINTENANCE

MAST TYPE: RAISE & LOWER HYRAULIC GL400, GL520 & GL620

WE STRONGLY RECOMMEND THAT THESE INSTRUCTIONS ARE READ CAREFULLY BEFORE ATTEMPTING ANY MAINTENANCE ON THIS EQUIPMENT.

The masts are of galvanised steel construction with tapering slip joint type multisided shafts. They can be identified by measuring the width of the base at hinge level. The width being 400, 520 & 620mm respectively. The illustration opposite shows a GL400 mast.

Maintenance requirements are minimal but the following checks are recommended at the intervals stated.

EVERY TIME THE MAST IS LOWERED

1. Check that all external hinge components are present and undamaged before attempting to lower the mast.
2. Check that the flexible conduits are not damaged.

EVERY 12 MONTHS

1. Check that all hinge components are present and undamaged.
2. Check the anti float bar is present and the screws securing it to the pivot are present and tight.
3. Check that the foundation bolts have not worked loose. The torque setting is as follows:

GL400 = 850Nm (8 No. M30 x 1220 G8.8)
GL400 = 1450Nm (8 No. M36 x 1200 G8.8)
GL520 = 1450Nm (8 No. M36 x 1200 G8.8)
GL620 = 1450Nm (16 No. M36 x 1350 G8.8)

4. Check that the upper and lower ram anchor gussets are not damaged.
5. Check warning label is attached to the base.
6. Check the door covers are secure and that the screw functions satisfactorily. Lightly grease the screw thread.

AS REQUIRED

1. Paint the shafts and base. Aesthetically the galvanised finish will typically last 5 - 7 years before painting is required. In polluted or saline environments this may be shorter and in a mild climate considerably longer.

Lubrication of the hinge assembly is not recommended.

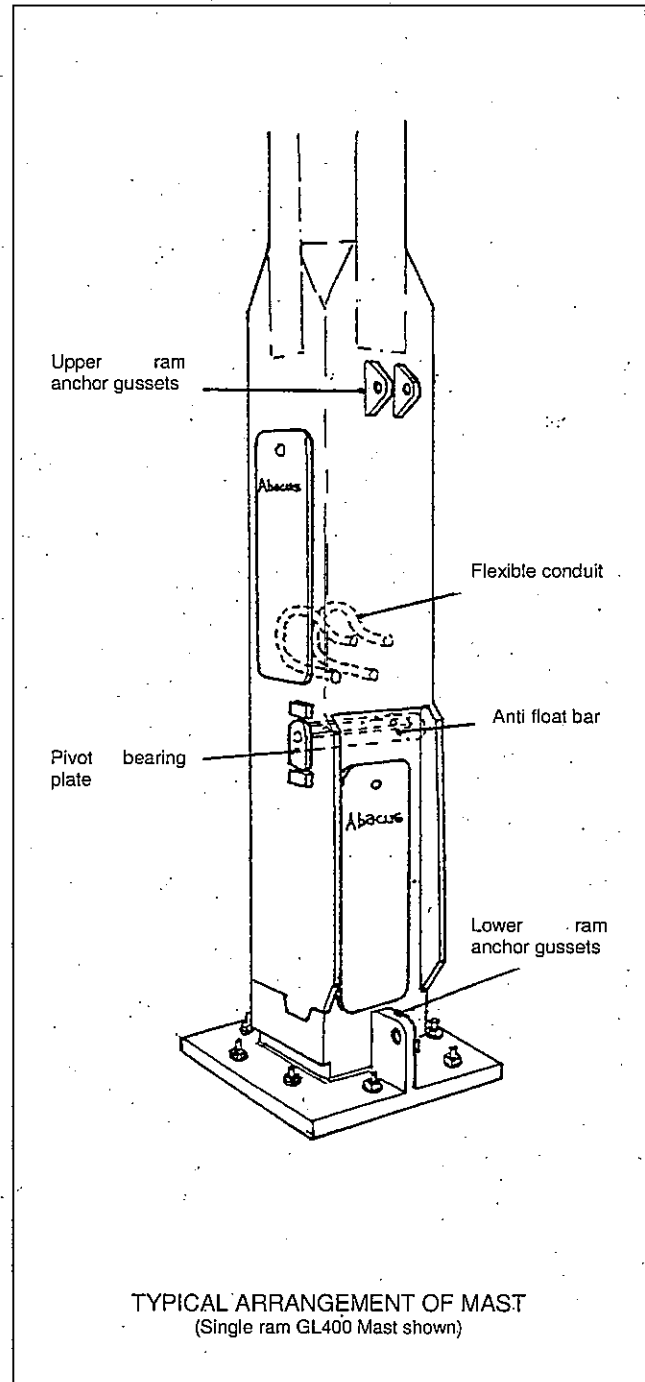

COUNTERBALANCE OPERATING INSTRUCTIONS

COUNTERBALANCE REF: Raise & Lower Hydraulic (RLH10, RLH11 & RLH12)

WE STRONGLY RECOMMEND THAT THESE INSTRUCTIONS AND THE HEALTH & SAFETY REQUIREMENTS SHEET SUPPLIED WITH THE UNIT ARE READ CAREFULLY BEFORE ATTEMPTING TO OPERATE THIS EQUIPMENT.

IF THERE IS MORE THAN ONE TYPE OF HYDRAULIC RAISE & LOWER MAST ON SITE, THEN EACH MAST SHOULD BE COLOUR CODED TO MATCH THE APPROPRIATE COUNTERBALANCE UNIT.

GENERAL

These units consist of a double acting hydraulic ram mounted on a trolley, which also houses the electrically driven pump unit, normally from a 240v supply. The counterbalances are individually colour coded and are used on GL300 and GL400 masts although other applications do occur. The selection of the correct unit depends on column type, height and headload. The units are as follows:-

RLH10 76mm bore ram – Colour coded white .	Weight 124kg	Rating 46260Nm
RLH11 101mm bore ram – Colour coded yellow .	Weight 138kg	Rating 85250Nm
RLH12 127mm bore ram – Colour coded black .	Weight 153kg	Rating 133380Nm

The rating refers to the maximum bending moment about the hinge of the mast. For details of the full range of **safe working loads** refer to the manufacturers mast data. **Note that the safe working load for a counterbalance unit varies with mast height.**

The pump unit is electrically operated with the pressure relief valve being set at 170bar (2500psi). **In the event of a hose failure a flow control valve, integral with the ram ensures that the mast lowers at a safe rate.** The valve is not adjustable. The ram is controlled by a 3 way, self centralising spool valve mounted on the motor/pump unit module. Because the spool valve is not fully leak proof, oil will slowly transfer from the rams to the tank. **It is essential that any trestle used to support the shafts, during maintenance is capable of carrying the load that will be transferred to it.**

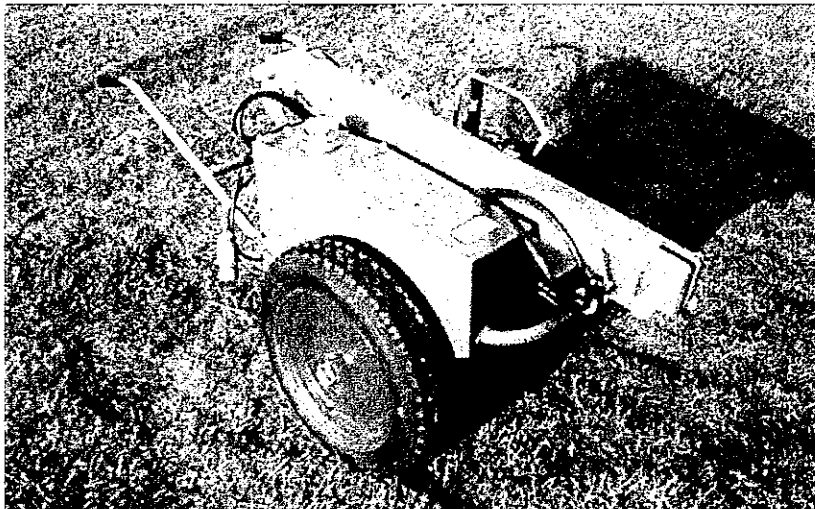

RLH11 COUNTERBALANCE
(RLH10 & RLH12 SIMILAR IN APPEARANCE)

The unit is supplied ex works with **Hydran 38F SAE 10 mineral oil** (or equivalent) in the tank. **For export the unit is supplied empty and the tank must be filled with oil before use.** The correct oil level is 30mm below the upper face of the filler port with the tank horizontal. Note that if this level is exceeded with the ram extended, oil will be ejected during operation of the equipment. The pump incorporates a breather unit/filler port in the top of the tank and when not in use the counterbalance should be stored with the tank in an upright position to avoid leakage.

PRELIMINARY CHECKS BEFORE USE

- 1 Examine the trolley framework for damage. Check that the wheels are operating and retained in position.
- 2 Examine the ram in particular the area around the seals for signs of damage and leakage of oil.
- 3 Check the oil level is 30mm below the upper face of the filler port with the tank top horizontal and the ram closed.
- 4 Check the hydraulic hoses and electrical flex for damage and loose connections.
- 5 Check that the upper and lower ram anchor pins are the correct diameter and colour code as follows:-

RLH10 – 25mm dia. Coded **white**
 RLH11 – 35mm dia. Coded **yellow**
 RLH12 – 38mm dia. Coded **black**

6 Check the function of the control valve by extending the ram a short distance and the retracting it. During extension the pressure should read 0 to 300psi. The pressure during retraction will be as follows:- RLH10 (1200psi), RLH11 (800psi) and RLH12 (600psi). As the rams fully close the pressure should rise to the relief valve pressure of 2500psi.

IF ANY OF THESE CHECKS ARE FAILED THE COUNTERBALANCE MUST NOT BE USED.

MOVING THE UNIT

Ensure when moving the unit that the ram is fully closed and is located in the hook shaped brackets located front and back of the trolley. The upper ram clevis is secured using the ram anchor pin.

The ram must be fully closed to securely fix it to the motor/pump unit.

ATTACHING RAM TO THE MAST

CAUTIONARY NOTE: ENSURE THE CORRECT MANUAL HANDLING TECHNIQUES ARE USED AT ALL TIMES WHEN LIFTING THE COUNTERBALANCE UNIT.

Connect the unit to a suitable power source either from within the mast base or via a portable generator, minimum 2.5Kva. With the ram attached to the motor/pump unit as described in the previous section, switch on the power supply and remove the lower ram anchor pin. Wheel the unit up to the mast and align the ram with the ram anchor gusset on the mast. Tilt the handles upwards and offer the lower end of the ram to the anchor gusset as indicated. Align the holes and insert the lower ram anchor pin and secure with the retaining pin provided.

With the pump unit still inclined, operate the control valve to extend the ram and allow the upper ram anchor pin to be released. Grasp the upper end of the ram and lift it towards the mast whilst simultaneously releasing the ram support/lifter bracket from the lower location bracket on the motor/pump body.

THE RAM IS FINELY BALANCED AT THIS POSITION AND MUST THEREFORE BE SUPPORTED AGAINST THE MAST BY HAND TO PREVENT IT BEING ACCIDENTALLY TOPPLED BACKWARDS.

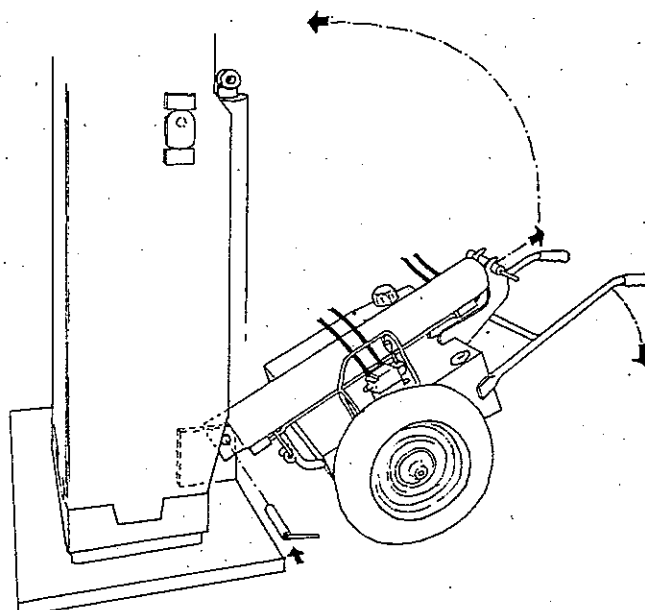

ATTACHING RAMS TO THE MAST

Extend the ram until the upper end is aligned with the upper ram anchor gusset. Insert the pin and secure with its retaining pin.

LOWERING THE MAST

DO NOT ATTEMPT TO LOWER THE MAST IF THE WIND SPEED IS 30KPH (18MPH) OR GREATER.

If the bearing plate has a locking screw, withdraw it using the door key, sufficient distance to allow the bearing plate to rotate. The relative positions of the pivot bearing plates for the various stages of the lowering and raising operation are shown in the operating sequence diagrams on sheets 7.27 and 7.28 and reference should be made to these.

Turn the bearing plate through 90° and pump the handle to extend the ram. As the ram extends, the hinged part of the mast will be observed lifting relative to the fixed part of the base. Continue pumping until the pivot reaches the limit of its travel and the bearing plate can be turned through a further 90° until they are pointing vertically upwards. Hold the bearing plate in position and reverse the control valve, which will allow the ram to retract. Pump the handle to retract the ram and initiate the lowering sequence. Once lowering has begun it is not necessary to continue pumping. There may be some slight vibration of the mast shaft at commencement of lowering as the various pivot and anchor pin clearances reverse, but this will cease very quickly to give a constant smooth descent.

Once a smooth descent is underway the control valve may be released to stop the mast in any desired position. When the mast reaches a horizontal position, place a suitable support below the shaft at approximately 2/3 of the mast height and at an overlap joint.

RAISING THE MAST

Rotate the control valve back to its original position. Operate the pump handle such that the ram extends and the hinged part of the shaft is raised into a vertical position.

ENSURE AS THE RAISING PROGRESSES THAT THE FLEXIBLE CONDUITS DO NOT GET TRAPPED BETWEEN THE FIXED AND HINGED PARTS OF THE MAST.

When the shaft has ceased oscillating, swing the bearing plate through 90° away from the bearing lug and reverse the control valve. Pump the handle to retract the ram. Check to ensure that the side plates have entered the slot between the base and gussets. When the side plates are fully engaged, rotate the bearing plate through a further 90° such that it is pointing vertically downwards and tighten the locking screw.

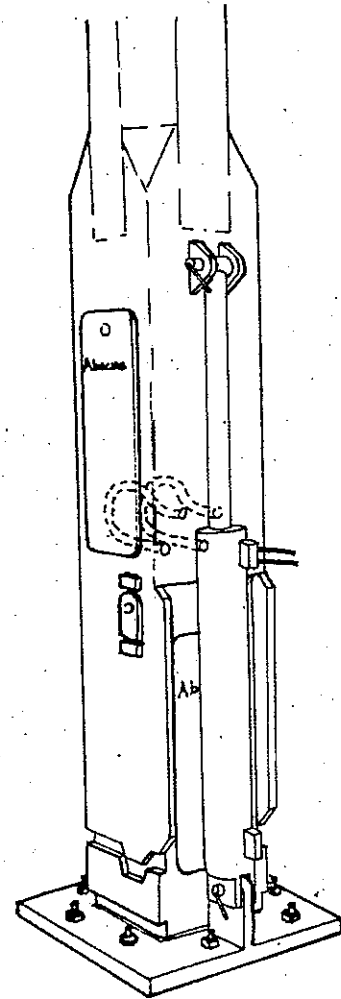

MAST IN RAISED POSITION

REMOVING THE RAM FROM THE MAST

CHECK THAT THE MAST IS PROPERLY DOCKED AND THAT THE BEARING PLATES ARE IN THEIR LOCKED POSITION.

Pull out the retaining pin and remove the upper ram anchor pin. Pull the ram out from between the gussets and refit the anchor and retaining pin. Support the ram against the mast and operate the control valve to retract the ram. Release the control valve when the ram is about 100mm short of being fully closed.

Offer the lower location bracket on the counterbalance up to the ram support/lifter bracket by swinging the ram backwards and tilting the motor/pump unit handles upwards as necessary. With the weight of the ram supported on the counterbalance, release the lower ram anchor pin and pull the unit away from the mast. Refit the pin to the ram and secure with its retaining pin.

7.162

iss 04/03

REMOVING THE RAM FROM THE MAST

Fully close the ram to engage the upper anchor pin in the location bracket on the counterbalance. **The ram must be fully closed with the ram anchor pin fitted to securely fix it to the motor pump unit.**

Switch off the electric motor and disconnect the power supply.

Refit the door cover to the mast, and secure with the retaining screw.

FOR FURTHER ADVICE CONTACT THE ABACUS TECHNICAL DEPARTMENT

COUNTERBALANCE ROUTINE MAINTENANCE

COUNTERBALANCE REF: Raise & Lower Hydraulic (RLH10, RLH11 & RLH12)

WE STRONGLY RECOMMEND THAT THESE INSTRUCTIONS ARE READ CAREFULLY BEFORE ATTEMPTING TO CARRY OUT MAINTENANCE ON THIS EQUIPMENT. PARTICULAR ATTENTION MUST BE PAID TO THE COUNTERBALANCE OPERATING INSTRUCTIONS AND ESSENTIAL HEALTH AND SAFETY REQUIREMENTS APPLICABLE TO THIS UNIT.

GENERAL

These counterbalance units are designed for use with GL300 and GL400 masts, although other applications do occur. The unit consists of a double acting hydraulic ram mounted on a trolley, which also houses the electric pump unit. The pump unit is driven by a 0.75kw, 240v electric motor and delivers oil to the rams via a 3 way spool valve and flexible hoses. Each unit is identified by a colour code on the upper end of the piston rod and also on the ram anchor pins. The colour codes are as follows:-

RLH10 76mm bore ram – Colour coded white .	Weight 124kg	Rating 46260Nm
RLH11 76mm bore ram – Colour coded yellow .	Weight 138kg	Rating 85250Nm
RLH12 102mm bore ram – Colour coded black .	Weight 153kg	Rating 133380Nm

The rating refers to the maximum bending moment about the hinge of the mast. For details of the full range of **safe working loads** refer to the manufacturers mast data. **Note that the safe working load for a counterbalance unit varies with mast height.**

The pump unit is manually operated with the pressure relief valve being set at 170bar (2500psi). **In the event of a hose failure a flow control valve, integral with the ram ensures that the mast lowers at a safe rate.**

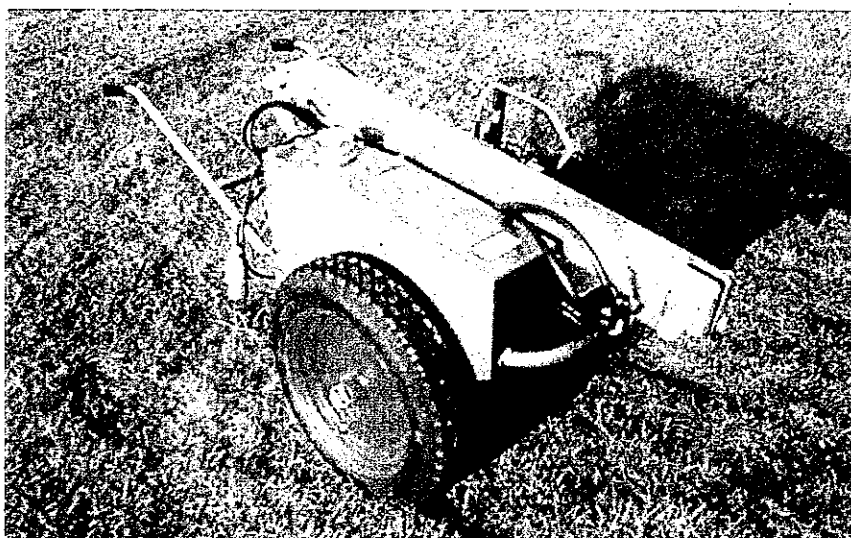

RLH11 COUNTERBALANCE
(RLH10 & RLH12 SIMILAR IN APPEARANCE)

The base of the ram is fitted with a flow control valve which will allow the mast to lower at a fixed rate in the event of a major hydraulic failure such as a severed hose. The valve is of the fixed orifice type and is not adjustable.

The hydraulic circuit is fitted with 3 filters. A suction strainer is fitted inside the reservoir, a return line filter is located below the tank and a micro strainer is located inside the flow control valve poppet. All filters are adequate for the life of this unit and will only need replacing if contaminated oil has been used to refill the tank.

ROUTINE MAINTENANCE

Due to its irregular usage it is difficult to specify a periodic maintenance schedule. However we recommend that the following simple checks be carried out at **12 monthly** intervals and any defective items replaced.

CAUTIONARY NOTE: THE WEIGHT OF THE RAMS IS AS FOLLOWS:- (RLH10) 39kg (RLH11) 53kg, AND (RLH12) 73kg. ENSURE THE CORRECT MANUAL HANDLING TECHNIQUES ARE USED AT ALL TIMES WHEN LIFTING OR MOVING THE RAM.

Check the oil level in the tank. This should be carried out with the tank as near horizontal as possible and with the ram fully closed. The oil level should be to the centre of the clear indicator panel on the tank side or to the level mark if one is provided. Tank capacity is 15 litres and should be topped up with **Hydran 38F SAE 10 mineral oil** (or equivalent). **Note that if the oil level is exceeded with the rams extended, oil may be expelled from the filler cap during lowering of the mast.**

Examine the hydraulic hoses that link the rams to the pump unit control block and ensure that the couplings and connections are firm, intact and free from leaks.

Check that the electrical flex and plug for damage and then connect it to the mains, ensure the same voltage is being used i.e. 110v, 240v or 415v. Check that the electric motor is running by operating the control valve to extend the ram a short distance. Operate the control lever to retract the ram. Both movements up and down should be smooth and jerk free.

Before attempting any work on the flow control valve ensure the ram is fully closed and supported in the vertical position, with the flow control valve uppermost. Switch off the electric motor and operate the flow control valve back and forth several times to depressurise the hydraulic circuit.

Clean the area around the large plug. Removing it will expose the spring and valve poppet. Check that the micro filter inside the valve poppet is present and remove. Clean and dry all components and check that the orifice (0.7mm bore) is unobstructed. Check that the filter has not collapsed due to heavy contamination. Carefully reassemble the components paying particular attention to cleanliness. Replace the bonded seal and plug and tighten securely.

The hydraulic ram can, if necessary be bled to remove any air that has entered the system. To do this requires the ram to be removed from the trolley and laid horizontally with the flow control valve blocks uppermost. (See cautionary note above). The procedure is as follows. First, slightly raise the top end of the ram and fully extend the piston. Second, slightly raise the flow control valve end of the rams and fully close. The ram can then be returned to the trolley.

Check that the flow control valve is functioning correctly. This is accomplished by extending the ram about 300mm then retracting it. During retraction the reading on the pressure gauge should not be less than 1200psi for the RLH10, 800psi for the RLH11 and 600psi for the RLH12. The pressure will increase to the relief valve pressure of 2500psi as the end of the stroke is reached. The movements of the ram, both up and down should be smooth and jerk free.

Ensure that the upper and lower ram anchor pins are present, undamaged and of the same colour code as the ram. These are as follows:-

RLH10 – 25mm dia. Coded **white**
RLH11 – 35mm dia. Coded **yellow**
RLH12 – 38mm dia. Coded **black**

ROUTINE MAINTENANCE

Check that the relief valve pressure is correctly set at 2500 ± 100 psi, by operating the control valve to retract the rams when they are already fully closed.

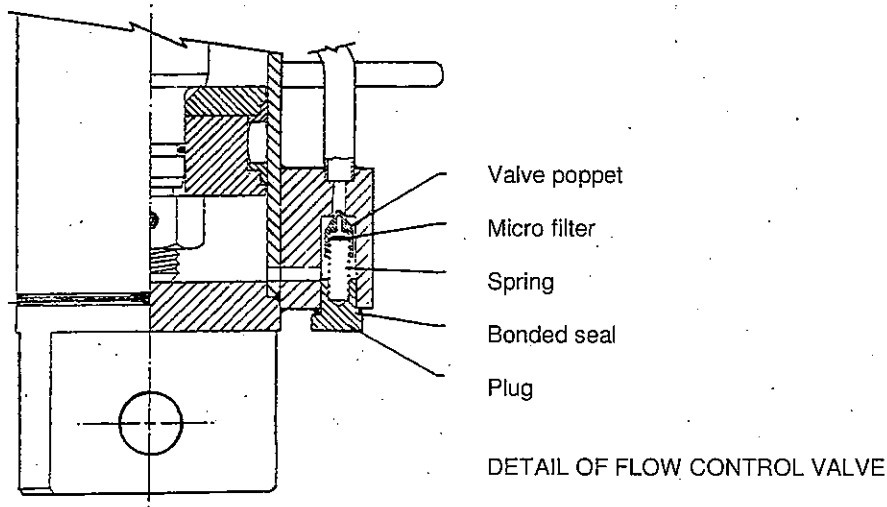

The pressure should rise quickly and stabilise at the correct value. If the reading is incorrect adjust the pressure relief valve setting as follows:-

The relief valve is located below or adjacent to the control valve. Some valves are fitted with a screwed cap which must be removed to allow the adjustment to be made. Hold the centre adjusting screw with an Allen key and slacken the locknut. With the ram fully closed, operate the control valve such that the relief valve pressure can be read on the pressure gauge. Turn the Allen key clockwise to increase the relief valve pressure and anticlockwise to decrease it. When the correct reading has been obtained, tighten the locknut and recheck the pressure setting. Refit the screwed cap if provided.

Examine the hydraulic ram, in particular the area around the seal, for any signs of damage and oil leakage. Fully extend the piston rod and check the polished surface for signs of bruising and corrosion pitting. Either will cause failure of the gland seals.

Check that the wheels on the unit are operational and retained in position. Where applicable the tyres should be fully inflated to a maximum pressure of 32psi.

DO NOT USE THE UNIT UNLESS ALL THESE CHECKS ARE SATISFACTORY.

**IN THE EVENT OF DAMAGE TO COMPONENTS OR FOR FURTHER ADVICE CONTACT THE ABACUS
TECHNICAL DEPARTMENT AT THE ADDRESS BELOW.**

OVOLINE

LUBRICANTS



HEAD OFFICE
Pipewellgate, Gateshead, Tyne & Wear, NE8 2BN
Tel: 0191 477 0854 Fax: 0191 490 0360
www.ovoline.co.uk

8000 HYDRAULIC OILS

PRODUCT DESCRIPTION

The Ovoline 8000 range hydraulic oils are manufactured using highly refined oils with high viscosity indices. These are blended with special additives to provide resistance to foaming, oxidation stability, low pour points, rust prevention and also anti-wear properties.

The Ovoline 8000 range hydraulic oils are recommended for hydraulic and circulating systems where a high grade lubricant with excellent wear resistance is required in order to reduce wear of working parts in the pump, valves etc. used. These lubricants have good demulsification characteristics to provide resistance to sludge formation and the development of acidity. Their pour points also make them suitable for use at low temperatures

BENEFITS

- Chemically & thermally stable.
- Excellent protection against rust.
- Excellent air release properties.

SPECIFICATIONS

- DIN 51524 Part 2, category HLP
- DIN ISO 6743 Part 3, category HM
- Afnor NF E 48-603
- Sperry Vickers M-2950-S & I-286-S.
- Denison HF-1, HF-2
- Denison Filterability I-286-S
- FZG Pass 11

TYPICAL TEST FIGURES

8000 Series	S.G. @ 15°C	Viscosity cSt	Viscosity Index	Pour Point °C	Flash Point °C PMCC
8005	0.842	4.6	-	-40	118
8010	0.868	9.5	2.3	-40	145
8015	0.873	14.5	3.1	-40	155
8022	0.874	22	4.3	-35	175
8032	0.874	32	5.4	-35	190
8037	0.874	37	5.9	-35	190
8046	0.877	46	6.7	-30	195
8068	0.885	68	8.6	-30	200
8100	0.892	100	11.3	-25	240
8150	0.984	150	14.7	-10	240

1. IDENTIFICATION OF THE SUBSTANCE / PREPARATION AND THE COMPANY

Identification of the substance/preparation : 8000 Series Hydraulic Oils
Comprising 8010, 8015, 8022, 8032, 8037, 8046 and 8068
(continued on MSDS 8000/2)

Product Type : Anti-Wear Hydraulic Oils [Type HM & HLP]

Application : Hydraulic oils with anti wear, antioxidant and corrosion
inhibiting characteristics.

Supplier : Ovoline Lubricants
Pipewellgate
Gateshead
Tyne & Wear
NE8 2BN

Tel : 0191 4770854

Fax : 0191 4900360

EMERGENCY TELEPHONE NO. : 0191 4770854 (Not 24 hours)

2. COMPOSITION / INFORMATION ON INGREDIENTS

Hazardous Ingredients : This product has no known hazards under applicable laws.

3. HAZARDS IDENTIFICATION

Principal Hazards : This material has no known health hazards.

SEE OTHER INFORMATION SECTION 11

4. FIRST AID MEASURES

Inhalation : Remove to fresh air. If effects persist, seek medical advice.

Skin contact : Wash thoroughly with large quantities of soap and water. Remove
contaminated clothing.

Eye contact : Flush eyes with large amounts of water until irritation subsides. If
irritation persists, get medical assistance.

Ingestion : If swallowed, DO NOT induce vomiting. Wash mouth out with water. Keep at
rest. Get prompt medical attention showing this sheet.

Pressure Injection : Always obtain immediate medical attention even though the injury
may appear minor.

5. FIRE FIGHTING MEASURES

Flammability :	Products not classified as flammable but are inherently combustible.
Flash Point (°C PMCC) :	From 145°C to 200°C
Fire fighting procedures :	Use foam or dry chemical to extinguish fire. Recommend wearing self-contained breathing apparatus. Use water spray to cool fire exposed surfaces. Shut off "fuel" to the fire. Leaks or spills which have not ignited should be dispersed by using water spray.
Special fire precautions :	Avoid spraying water directly into storage containers due to danger of boil over.
Products of combustion :	Smoke, Oxides of carbon, nitrogen, sulphur and phosphorus. Toxic vapour.

6. ACCIDENTAL RELEASE MEASURES

Personal Precautions :	Spilt product presents a significant slip hazard. Avoid exposure of the product to sources of ignition. Personal Protective Equipment must be worn. Section 8
Environmental Precautions :	Prevent entry into drains, sewers or water courses.
Decontamination Procedures :	Soak up with inert absorbent or contain and remove by pumping or best available means. In case of spillage on water contain by a boom and collect by skimming or absorption.

7. HANDLING & STORAGE

Keep container closed.
Store drums under cover in racking protected from mechanical impact. If stored outside ingress of water should be avoided, e.g. by placing containers on their side and raising off ground.
Avoid sources of heat or ignition.
A bunded storage area may be required.
Odourous and toxic fumes may form from the decomposition if stored at temperatures in excess of 45°C for extended periods of time or if heat sources > 121°C are used..
Compatible with most common metals.
May soften certain rubbers.
Provide suitable mechanical equipment for the safe handling of drums and heavy packages.
Do not reuse empty containers without commercial cleaning or reconditioning.

Storage Temperature : Between 0°C and 40°C

8. EXPOSURE CONTROLS / PERSONAL PROTECTION

OCCUPATIONAL EXPOSURE LIMITS (OEL) :	Substance	8-Hour TWA	STEL	Source / Other Information.
	Mineral Oil (see oil mist, mineral)	5mg/m3	10mg/m3	EH40
Engineering Control Measures :	Local exhaust ventilation is recommended when excessive product misting occurs.			
Personal Protection :	Avoid skin and eye contact, wear safety glasses with side shields, long sleeves and chemical resistant gloves (Neoprene) in case of repeated or prolonged contact. Chemically protective boots when necessary to avoid contaminating shoes. Do not wear rings, watches or similar apparel that could entrap the material and cause a skin reaction. Change contaminated clothing and thoroughly clean before reuse.			

9. PHYSICAL AND CHEMICAL PROPERTIES

Blend :	8010	8015	8022	8032	8037	8046	8068
Appearance :	Mobile liquids						
Odour :	Characteristic mineral oil						
Pour Point / Melting Point (°C) :	-40	-40	-35	-35	-35	-30	-30
Boiling Point / Range (°C) :	Not available						
Flash Point (PMCC °C) :	145	155	175	190	190	195	200
Auto flammability (°C) :	Not available						
Explosive Properties (%) :	Not available						
Relative Density kg/l (15.5°C) :	0.868	0.873	0.874	0.874	0.874	0.877	0.885
Water Solubility :	Negligible						
Fat Solubility :							
Kinematic Viscosity at 40°C (mm ² s ⁻¹) :	10	15	22	32	37	46	68

PLEASE NOTE THAT THESE PROPERTIES DO NOT CONSTITUTE A SPECIFICATION

10. STABILITY AND REACTIVITY

Stability :	Stable, will not polymerise
Conditions to avoid :	Temperatures (°C) above 60
Materials to Avoid :	Strong oxidising agents. Acids.
Hazardous Decomposition Products :	Irritant fumes. DO NOT breathe products of decomposition. Smoke, oxides of carbon, nitrogen, sulphur and phosphorous, Hydrogen sulphide, alkyl mercaptans, and sulphides may also be released.

11. TOXICOLOGICAL INFORMATION

The following toxicological assessment is based on a knowledge of the toxicity of the products components.
Estimated oral LD50, rat > 5g/kg : rabbit > 2g/kg

HEALTH EFFECTS

On Eyes : Not expected to cause irritation.

On Skin : Unlikely to cause harm on brief or occasional contact.

By Inhalation : Low volatility makes inhalation unlikely at ambient temperatures.

By Ingestion : May cause nausea, vomiting and diarrhoea.

Chronic : Frequent or prolonged contact may lead to skin disorders.

Other : Products which have become contaminated in use or from external sources may present more serious health effects. Engine Oils become contaminated during use and generate potential carcinogens. Avoid skin contact with used Engine Oils.

12. ECOLOGICAL INFORMATION

Biodegradability : <50 % (CEC L-33-T-82) Chemical Oxygen Demand (mgO₂/l) : Not Determined.

Mineral oils are inherently but not readily biodegradable.
Leaching and penetration of mineral oils through surface soils is generally regarded as resulting in long term persistence.
Fresh or used mineral oils may be harmful to aquatic life.

13. DISPOSAL CONSIDERATIONS

Place used and contaminated materials / packaging in suitable containers. Dispose of the controlled waste in accordance with Duty of Care regulations (Environmental Protection Act 1990 - Section 34(7)) using a licensed waste disposal company.

14. TRANSPORT INFORMATION

Classification for Transport : NOT CLASSIFIED AS HAZARDOUS FOR TRANSPORT

UN Number :	N/A	Packaging Group :	N/A
Shipping name :	N/A		
IMO Class :	N/A	Marine Pollutant :	NO
ADR/RID :	N/A	ICAO/IATA :	N/A

15. REGULATORY INFORMATION

Hazard Label Data : These products are not classified as dangerous for supply in the UK.

EC Directives : Framework Waste Directive, 91/156/EEC
 Waste Oil Directive, 87/101/EEC

Statutory Instruments : The Health and Safety at Work, etc. Act 1974
 Consumer Protection Act 1987
 Environmental Protection Act 1990
 Control of Substances Hazardous to Health Regulations 1994
 Chemicals (Hazard information and Packaging) Regulations 3

16. OTHER INFORMATION

The data and advice given apply when the products are sold for the stated application or applications. The products are not sold as suitable for any other application. Use of the products for applications other than as stated in this sheet may give rise to risks not mentioned in this sheet. You should not use the products other than for the stated application or applications without seeking advice from us.

If you have purchased the products for supply to a third party for use at work, it is your duty to take all necessary steps to ensure that any person handling or using the products is provided with the information in this sheet.

If you are an employer, it is your duty to tell your employees and others who may be affected of any hazards described in this sheet and of any precautions which should be taken.

Approved Codes of Practice : Waste Management. The Duty of Care.

Guidance notes : EH/26 Occupational Skin Diseases : Health and Safety Precautions
 EH/40 Occupational Exposure Limits
 EH/58 The Carcinogenicity of Mineral Oils
 MS(B)5 Skin Cancer Caused by Oil.
 MS(B)6 Save your skin! - Occupational Contact Dermatitis
 SHW 367 Dermatitis - Cautionary Notice
 SHW 397 Effects of Mineral Oil on the Skin

The above publications are available from HMSO and HSE sources.

Abacus[®]

Leaders in Lighting

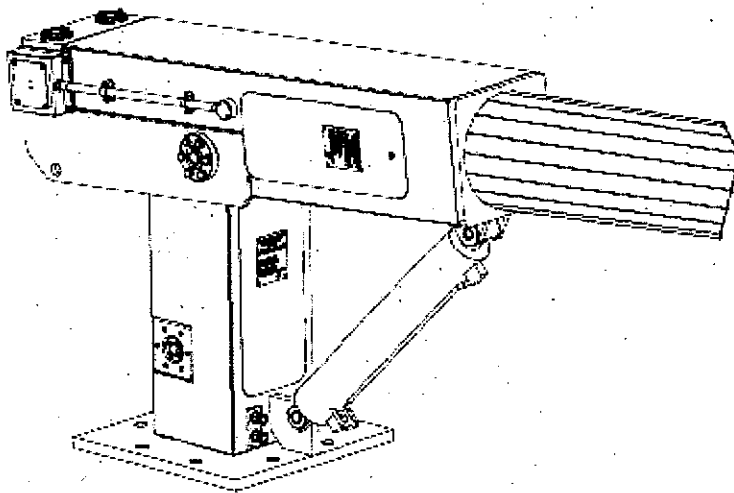

Automatically Sequenced
Base Hinged Masts

Applicable products:

- GL40022SEQ/A3645

Product Manual

3rd March 2014

**WE STRONGLY RECOMMEND THAT THESE INSTRUCTIONS
ARE READ CAREFULLY BEFORE ATTEMPTING TO INSTALL,
OPERATE AND MAINTAIN THIS EQUIPMENT**

Product Manual

3rd March 2014

1. Introduction	2
2. Supplier's Details	2
3. Mast Positioning	2
4. Physical Installation	2
4.1. General	2
4.2. Equipment Required (not Abacus supply)	3
4.3. Mast Assembly & Installation	3
4.4. Torque Settings For Bolts	5
5. Electrical Connection	7
6. Description of Control System	7
7. Remote / Auxiliary Connectivity	7
8. Operation	8
8.1. Commissioning raising and lowering system	8
8.2. General	10
9. Maintenance	10
9.1. General	10
9.2. Post warranty maintenance requirements	11
9.3. Mast	11
9.3.1. Every Time Mast is Lowered	11
9.3.2. Every 12 Months	11
9.3.3. As Required	12
9.4. Hydraulic Systems	12
9.4.1. General	12
9.4.2. Routine Maintenance	13
10. Environmental Advice	15
Appendix A - Electrical Drawings	
Appendix B - Electrical Datasheets	
Appendix C - Electrical Parts List	
Appendix D - Mechanical Drawings	

1. Introduction

This document is intended for use as a guide to the sequencing mast installation for the Victoria Sports Centre and fulfils the requirements of the Construction (Design and Management) Regulations 2007.

The system has been designed in accordance with the guidelines set out in BS7671 (the 17th Edition IEE wiring regulations) in particular section 559 (Luminaries and Lighting Installations) as published by the Institute Of Electrical Engineers, London.

2. Supplier's Details

The sequencing masts and control cabinets were provided by:

Abacus Lighting Ltd
Sutton in Ashfield
Nottinghamshire
United Kingdom
NG17 5FT

Telephone +44 (0)1623 511111
Facsimile +44 (0)1623 552133
Email sales@abacuslighting.com

3. Mast Positioning

A base hinged mast must be positioned so that the area into which it can be lowered is free from obstructions.

If an automatically sequenced mast is remotely controlled it is important that access to the lowering zone is controlled and suitable warning are posted in the vicinity. The lowering time of the mast is approximately 5 minutes.

4. Physical Installation

4.1. General

The foundation bolts should be cast in to the concrete foundation 3 to 4 weeks prior to erection of the mast to allow time to cure. Foundation block dimensions for a variety of ground conditions can be supplied on request.

Each mast is supplied in kit form for on-site assembly. The shafts are slotted together and require no on site welding or bolting.

Because these masts are designed for specific applications it is essential that reference is made to the engineering drawings during assembly. These will give details of 'design' and 'minimum' overlaps. The 'design' overlap is the theoretical overlap which should be achieved. Manufacturing

tolerances may initially prevent this figure from being reached although some in-service settlement will occur. The 'minimum' overlap is the overlap which must be achieved for full structural performance. The minimum permissible overlap can also be determined from Fig. 1.

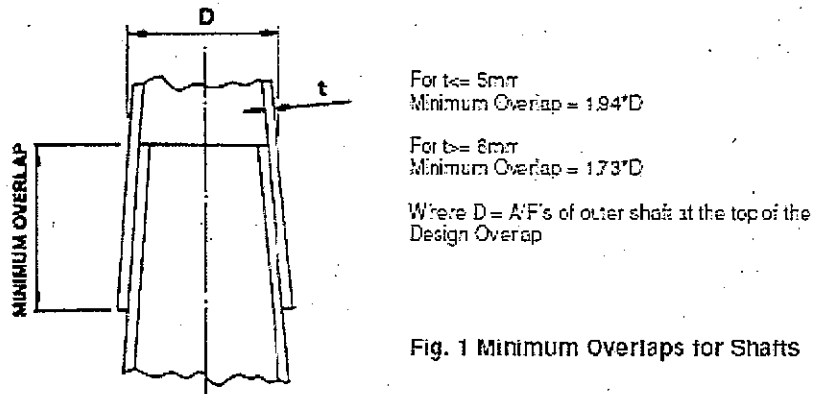

Fig. 1 Minimum Overlaps for Shafts

4.2. Equipment Required (not Abacus supply)

- 1 no. 3.0 tonne Tirfor c/w wire ropes.
- Various wire ropes, soft slings and shackles
- Supply of liquid soap
- $\text{Ø}30$ steel bar or steel beam with attachment points for 'D' shackles
- Supply of timber supports and packing
- Mobile crane to lift mast and headframe, typically 5 tonne
- Torque multiplier and wrench

4.3. Mast Assembly & Installation

For export orders the masts will be containerised. If the smaller shafts are fitted inside larger ones, they will need to be carefully unpacked on site to avoid damaging the galvanised finish.

The powerpack should be situated within the cabinet and hydraulic hoses, electrical and control cables routed through the ducting to the mast foundation.

The holding down bolts are each fitted with two nuts and washers. The upper nuts, washers and template should be removed. The threads should be examined for any damage and rectified using a die nut if necessary. The nuts should be set in level plane using a steel bar and spirit level across each opposing pair of nuts. Check that the base section is fully closed and that the locking pins are extended. Using a crane lift the column base and place over the foundation bolts and on to the lower set of nuts, threading all hoses and cables into the mast base. Ensure the direction of lowering is as required and that the mast will clear any obstructions.

Fit the retaining washers and nuts to the bolts and roughly 'plumb up' the mast (levelling will be easier if only 4 levelling nuts are initially used). Tighten the retaining nuts to hand tight plus half a turn. There is no need to apply full torque to the nuts at this stage.

Refer to the commissioning section of the operating instructions (section 8.1) and lower the mast base to the horizontal position.

Before assembly lay the shaft sections end to end on the ground and ensure by sighting from one end that the shafts are straight. Check the overlap area for any damage, excess zinc or weld which

may impede fitting of the shafts together and rectify if necessary. It may be necessary to rotate one or all of the sections to achieve the best alignment. Care should be taken to ensure that seam welds on adjoining shafts are not in line.

Mark the minimum overlap position on the stub shaft of the mast using the method described in Fig 1. With the base section lowered, pick up, locate and slide home as far as possible the larger shaft sections. Ensure the flats do not rotate relative to each other since a shaft wedged with a corner to a flat will be very difficult to separate. Refer to Fig. 2 for details.

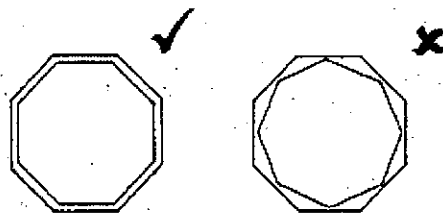

Fig. 2 Shaft Orientation

(Typically 16 sided. 8 sides shown for clarity)

The minimum overlap distance must be covered and in most cases exceeded. To achieve this it may be necessary to mechanically pull the shafts together.

For smaller shafts this may be achieved by knocking the shaft with a hammer, ensuring that a wooden block is placed over the end of the shaft which is to be hit. Smearing liquid soap over the end of each inner shaft before assembly may also help.

For larger shaft sections, which require assembly by mechanical means it will be necessary to use a Tirfor with a pulling capacity of 3000Kg. Position the Tirfor within the side door of the mast base and attach it via a wire rope and a steel bar to the open base of the mast. Feed the Tirfor wire down the length of the two shafts being assembled and connect it to an attachment plate or bar as illustrated. Protect the shaft edges from deformation using timber packers. The Tirfor wire can then be tensioned and the shaft pulled into position whilst at the same time agitating the shaft up and down. As sliding takes place periodically sight down the assembly to check for straightness. Ensure the minimum overlap has been achieved and remove the attachment plate in readiness for pulling the next shaft into position. Remove any surplus soap from the base section. Repeat the procedure for all remaining shafts. Remove the equipment before attempting to operate the mast.

Fit the floodlight mounting bracket to the top shaft section and secure with the screws provided. It should be noted that the power supply cable can be installed during assembly or, if preferred, after assembly is completed, but prior to fixing the floodlighting bracket. All the electrical work should now be carried out.

Refer to the commissioning section of the operating instructions (section 8.1) and raise the mast to the vertical position.

After completion of assembly and with the mast raised, recheck for vertical alignment. Slightly slacken the retaining nuts and use the lower set of nuts to accurately 'plumb up' the mast. It should be noted that the base sides are parallel, whereas the shafts are tapered. Once satisfactory all bolts should be tightened to the required torque setting (section 4.4).

If the gap below the flange is to be grouted it is essential that adequate provision is made for ventilation and drainage of any water collecting inside the base.

The mast can then be commissioned.

'Plumbing up' in warm weather or climates. To minimise the effect of the sun on one side of the mast, which can cause considerable temporary curvature of the mast it is recommended that the 'plumbing up' be carried out very early or late in the day.

4.4. Torque Settings For Bolts

Diameter	Bolt Size Torque Setting (Nm)	
	Grade 4.6	Grade 8.8
M20	50	250
M24	160	425
M30	310	850
M36	550	1450
M42	875	2350
M48	1300	3500

ASSEMBLY AND INSTALLATION INSTRUCTIONS FOR GRANDELUME MAST
(SINGLE RAM COUNTERBALANCE SHOWN FOR CLARITY - PROCEDURES ARE THE SAME FOR TWIN UNITS)

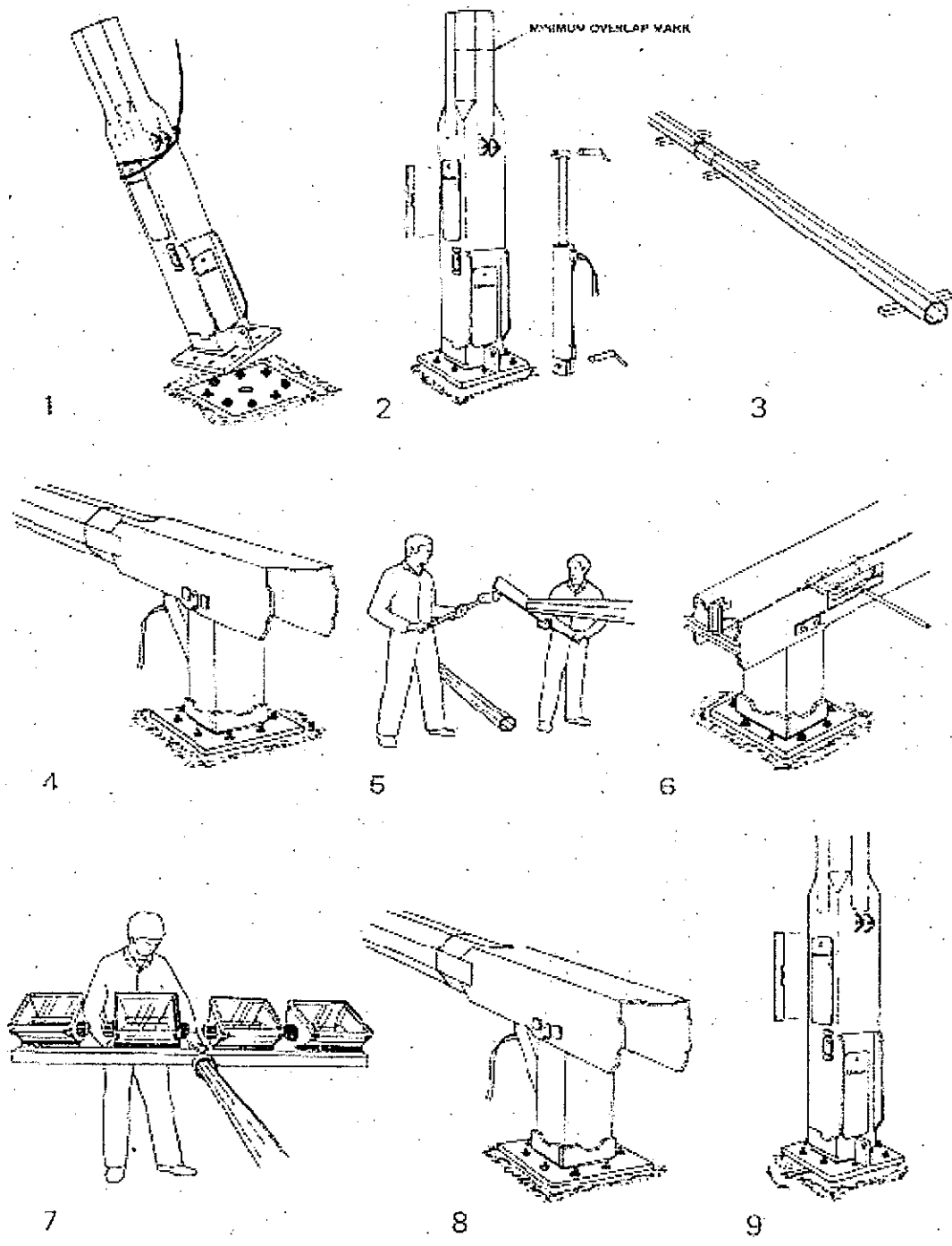

5. Electrical Connection

The electrical connection to the control system should be made via a suitably selected protective device and supply cable. Consideration should be given to the start up current associated with inductive motors and inductive solenoid coils. Please refer to electrical drawings associated system loads.

NOTE: GREAT CARE SHOULD BE TAKEN WHEN USING ELECTRICALLY OPERATED EQUIPMENT. REPORT ANY FAULTS OR DAMAGED EQUIPMENT AS SOON AS POSSIBLE.

IF IN DOUBT CONSULT A QUALIFIED ELECTRICIAN

6. Description of Control System

Each mast is provided with a Hydraulic Mast Control Panel which have the following indicators and function buttons.

- Up Button
- Down Button
- Emergency Stop Button
- Motor Running Indicator
- Mast Up Indicator
- Mast Down Indicator
- Socket Outlet
- Interlocking Door Isolator

Please refer to drawings for the arrangement of above.

The control system also consists of a programmable controller, relays and contactors all housed within a mild steel powder coated IP66 control panel.

Please refer to technical data sheets and drawings for exact specifications and working parameters of internal components.

7. Remote / Auxiliary Connectivity

The system has the facility for connecting remote switches and indicators with terminals provided in the system control panel. Careful consideration should be given to the remote connection which needs to be of the correct voltage and format. The following functions are provided for.

1. Column Up Contacts.
Function:- Column up remote Indicator and/ or floodlight inhibit signal.
Format Provided:- Volts Free Contact.
2. Column Down Contacts.
Function:- Column Down remote Indicator.
Format Provided:- Volts Free Contact.

3. **Warning Beacon Switch.**
Function:- Audible/ Visual Warning while mast is in operation.
Format Provided:- Switched 24 Volts.
4. **Run Column Up.**
Function:- Remote Column Up Signal.
Format Provided:- Terminal direct onto PLC controller. Switch using No Volt contacts, Momentary Pulse Only.
5. **Run Column Down.**
Function:- Remote Column Down Signal.

Format Provided:- Terminal direct onto PLC controller. Switch using No Volt contacts, Momentary Pulse Only.
6. **Emergency stop.**
Function:- Remote Emergency stop.
Format Provided:- Terminal direct onto PLC controller. Switch using No Volt contact, with Mechanical Latching Contacts.

Please refer to the wiring diagrams provided before adding any remote switches or indicators.

8. Operation

8.1. Commissioning raising and lowering system

<p>Please read carefully before commissioning the mast. Turn system OFF before removing/replacing any wire links.</p>

Once the base section of the mast has been installed on the holding down bolts and approximately levelled (section 4.3) the hinge mechanism must be commissioned to check its operation and to lower the stub for further mast assembly.

Connect all hydraulic hoses between the powerpack outlets and the main ram and locking pin rams as per the layout diagram below (Figure 8-1).

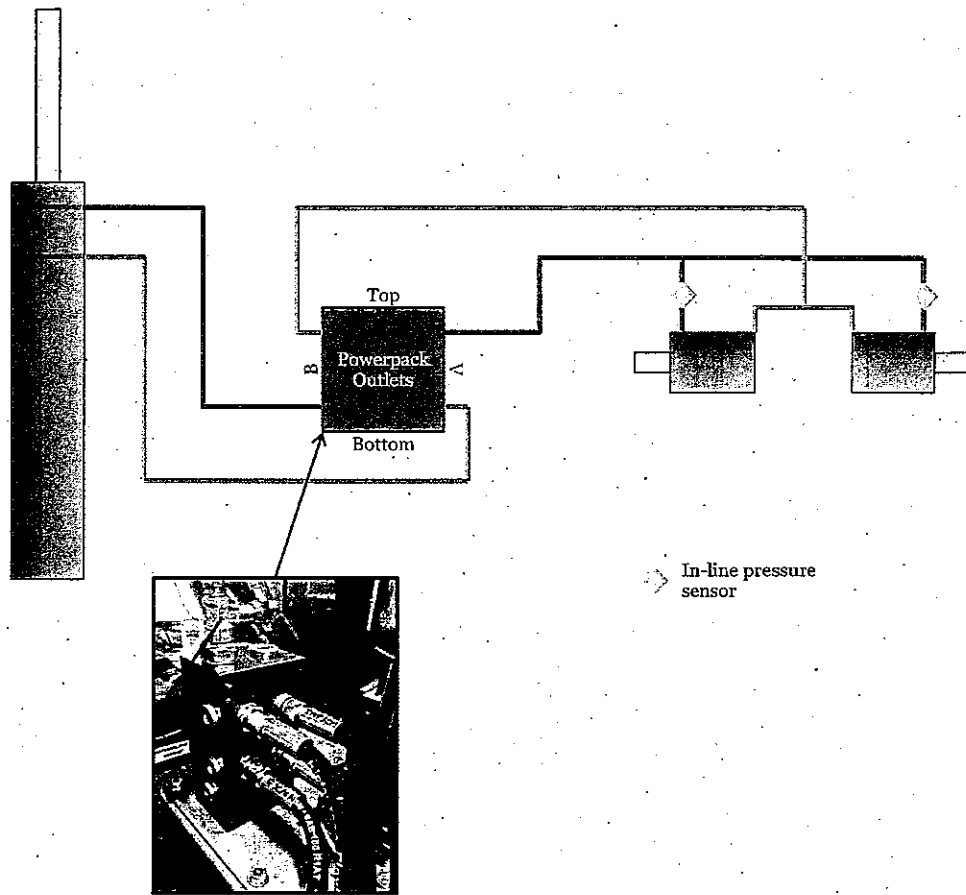

Figure 8-1

Connect all sensor leads as per the electrical drawings (Appendix A).

In normal use, the mast raises and lowers by following a series of steps controlled automatically by various system sensors. During commissioning the sequence is carried out manually to ensure correct alignment has been achieved at each stage.

The control system is configured to run in commissioning mode by removing the wire link labelled 100, connected to input IG of the programmable controller. While in this mode the mast's locking pins will be in manual mode and require the commissioning engineer to hold the up button in so the 'extend locking pins' part of the sequence executes. With the locking pin sensor cover removed the commissioning engineer should adjust the Nylon spacer pads on the mast lid to align the locking pins with their associated holes. Once alignment has been achieved, the locking pin sensor cover should be replaced and the link labelled 100 should be replaced to input IG. This will put the system back into fully automatic mode.

8.2. General

Please ensure the mast and control system have been fully commissioned before operating the system in normal use.

Turn the isolator handle to the on position.

With the mast in the lowered position: Press the up button and the motor running light will illuminate to indicate the hydraulic pack has started and the mast will raise to the up position and then the mast up light will illuminate and the system will automatically stop. Please note once the mast has reached the up position there will be a delay before the hydraulic pack stops, because the locking pins need time to locate.

With mast in the up position: Press the down button and the motor running light will illuminate to indicate the hydraulic pack has started. Please note there will be a short delay before the mast starts to lower because the locking pins need time to retract. Once the mast lowers to the down position the mast down indicator will illuminate and the system will automatically stop.

If during the operation of the mast the operator needs to stop the system then the emergency stop button should be pressed until it locks into the in position. To restart the system the emergency stop button should be pulled out and the desired up or down button pressed.

The control system monitors the Hydraulic Motor Pack and indicates when the overload for the motor has tripped. If the system indicator lamp is illuminated then seek help from a suitably qualified electrician to investigate the fault.

9. Maintenance

9.1. General

Abacus lighting is able to provide a full maintenance service for this system. Included within a yearly inspection of the system would be the following:

- Lowering the mast and checking operation.
- Cleaning the floodlight and re-aiming where necessary.
- Checking and inspecting the floodlight lamp and control gear.
- Inspection of the foundation assembly (visual only).

Yearly inspection and certification of the electrical system can be provided in accordance with BS7671.

All Abacus installed systems are provided with a full NIC Electrical Inspection Test certificate. The certificate gives a recommended date for the next electrical inspection. We also recommend that an annual visual inspection is carried out on the mast gear enclosures and pitch side cabinets to check for:

- Vermin damage.
- Ingress of moisture and other solid foreign bodies.
- Component malfunction.
- Signs of overheating.

- Vandalism.

9.2. Post warranty maintenance requirements

Abacus floodlighting installations are designed, manufactured and installed to the highest standards, using only quality components in accordance with all applicable British and European harmonised standards. However some of the components such as lamps and capacitors have a serviceable life, and as such Abacus recommends that installations are inspected annually to ensure the floodlighting continues to function correctly and safely.

The installation should be inspected, tested and certified electrically safe in accordance with the requirements of BS7671 Electrical Wiring Regulations. As with all fixed electrical installations, it is recommended that the floodlighting is further periodically inspected to ensure its continued safety. On Abacus installed schemes, the recommended period between inspections for an installation is shown at the bottom of page 2 of the supplied Electrical Installation Certificate. This period is usually between 2 to 5 years depending on location, type of installation and hours of use.

Abacus can incorporate an electrical Periodic Inspection Report into one of our maintenance packages to suit various needs/budgets. Please see attached literature.

Although regular maintenance greatly increases the working life and safety of the floodlights, Abacus cannot accept responsibility for damage to equipment or failure of the floodlighting outside the warranty period. Extended warranties are available upon request.

9.3. Mast

The masts are of galvanised steel construction with tapering slip joint type multisided shafts.

Maintenance requirements are minimal but the following checks are recommended at the intervals stated.

9.3.1. Every Time Mast is Lowered

- Check that all external hinge components are present and undamaged before attempting to lower the mast.
- Check that the flexible conduits are not damaged.

9.3.2. Every 12 Months

- Check that all hinge components are present and undamaged.
- Check the anti float bar is present and the screws securing it to the pivot are present and tight.
- Check that the foundation bolts have not worked loose. The torque setting is as follows:
GL400 = 850Nm (8 No. M30 x 1220 G8.8)
- Check that the upper and lower ram anchor gussets are not damaged.
- Check warning label is attached to the base.

- Check the door covers are secure and that the screw functions satisfactorily. Lightly grease the screw thread.

9.3.3. As Required

- Paint the shafts and base. The galvanised finish will typically last 5 - 7 years before painting is required. In polluted or saline environments this may be shorter and in a mild climate considerably longer.

The main hinge assembly is fitted with a polymer bearing which provides low friction operation for life. Under no circumstances should the hinge assembly be lubricated. Lubricants will attract contaminants which will damage the bearing surfaces.

9.4. Hydraulic Systems

Counterbalance tank capacity = 23 litres

Recommended oil:

- Fuchs Agrifarm Universal HV 46

Alternative equivalent mineral oils can be used, examples listed below:

- Ovoline 8000 Range - 8046
- Shell Tellus 37 SAE 10
- Fuchs Agrifarm Universal HV 46

Note: All Counterbalances for export are drained prior to despatch and require the hydraulic oil sourcing locally. All Counterbalances for the UK are despatched with the correct hydraulic oil and amount in accordance to the counterbalance reference.

9.4.1. General

The system consists of a double acting hydraulic ram mounted permanently to the outside of the mast for raising and lowering, two internal double acting rams for locking the mast and a powerpack unit housed in the adjacent cabinet. The powerpack pump is driven by a 0.75kw, 240v electric motor and delivers oil to the rams via a 3 way spool valve and flexible hoses.

The pump unit is operated with the pressure relief valve being set at 170bar (2500psi). In the event of a hose failure a flow control valve, integral with the ram ensures that the mast lowers at a safe rate. The valve is of the fixed orifice type and is not adjustable.

The hydraulic circuit is fitted with 3 filters. A suction strainer is fitted inside the reservoir, a return line filter is located below the tank and a micro strainer is located inside the flow control valve poppet. All filters are adequate for the life of this unit and will only need replacing if contaminated oil has been used to refill the tank.

9.4.2. Routine Maintenance

Due to its irregular usage it is difficult to specify a periodic maintenance schedule. However we recommend that the following simple checks be carried out at 12 monthly intervals and any defective items replaced.

Check the oil level in the tank. This should be carried out with the tank as near horizontal as possible and with the ram fully closed (mast lowered, locking pins retracted). The oil level should be to the centre of the clear indicator panel on the tank side or to the level mark if one is provided (Figure 9-1). Tank capacity is 15 litres and should be topped up with Fuchs Agrifarm Universal HV 46 mineral oil (or equivalent).

Note: If the oil level is exceeded with the rams extended, oil may be expelled from the filler cap during lowering of the mast.

Examine the hydraulic hoses that link the main lifting ram and locking pin rams to the pump unit control block and ensure that the couplings and connections are firm, intact and free from leaks.

Check that the electrical flex and plug for damage.

Further maintenance on the hydraulic system should only be undertaken by suitably qualified personnel. If any ram needs to be removed it is important that a bar is placed through the locking hole on the lower front edge of the lid (Figure 9-2). This ensures the mast cannot lower even when all hydraulic systems are removed.

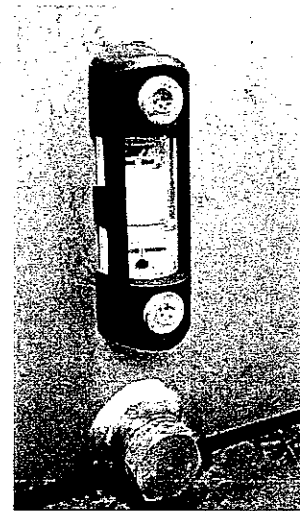

Figure 9-1

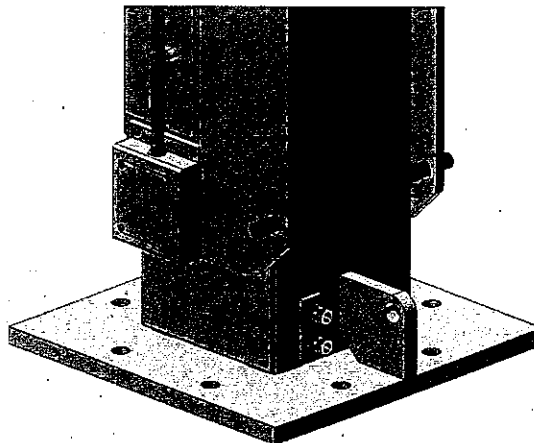

Figure 9-2

Note: The weight of the main ram is 73kg. Ensure the correct manual handling techniques are used when lifting or moving the ram.

Before attempting any work on the hydraulic system, switch off the control panel and manually depress the main cylinder valve solenoid (Figure 9-3) several times to depressurise the hydraulic circuit.

The hydraulic ram can, if necessary be bled to remove any air that has entered the system. To do this requires the ram has to be removed from the mast and laid horizontally with the flow control valve blocks uppermost. The procedure is as follows. First, slightly raise the top end of the ram and fully extend the piston (see hinge commissioning section 8.1). Second, slightly raise the flow control valve end of the rams and fully close. The ram can then be returned to the mast.

Check that the flow control valve is functioning correctly. This is accomplished by extending the ram about 300mm then retracting it. During retraction the reading on the pressure gauge should not be less than 600psi. The pressure will increase to the relief valve pressure of 2500psi as the end of the stroke is reached. The movements of the ram, both up and down should be smooth and jerk free.

Check that the relief valve pressure is correctly set at 2500 ± 100 psi, by operating the control valve to retract the rams when they are already fully closed. The pressure should rise quickly and stabilise at the correct value. If the reading is incorrect adjust the pressure relief valve setting as follows:-

The relief valve is located below or adjacent to the control valve. Some valves are fitted with a screwed cap which must be removed to allow the adjustment to be made. Hold the centre adjusting screw with an Allen key and slacken the locknut. With the ram fully closed, operate the control valve such that the relief valve pressure can be read on the pressure gauge. Turn the Allen key clockwise to increase the relief valve pressure and anticlockwise to decrease it. When the correct reading has been obtained, tighten the locknut and recheck the pressure setting.

Refit the screwed cap if provided.

Examine the hydraulic ram, in particular the area around the seal, for any signs of damage and oil leakage. Fully extend the piston rod and check the polished surface for signs of bruising and corrosion pitting. Either will cause failure of the gland seals.



Figure 9-3

10. Environmental Advice

Operatives should be familiar with the requirements of the following documentation-

- Pollution Prevention and Control Regulations
- Control of Pollution (Oil Storage) Regulations
- Control of Substances Hazardous to Health Regulations
- Hazardous Waste Regulations
- Environmental Protection Act

+The mast counterbalance incorporates the use of hydraulic oil for raising and lowering operations.

The counterbalance unit has an oil reservoir, sited within the cabinet adjacent to each mast.

Each reservoir has a 'breather cap' on top of the tank which is required for using a hydraulic system. The breather cap will leak out oil if the unit is tipped at any point therefore it must be kept upright to prevent this from happening.

Before operation ensure that all the hydraulic hoses are connected properly to prevent any spillages when in use.

If you store or use oil you should be prepared for any spillages, keeping a stock of absorbent materials and ensuring the operatives are trained to deal with any spills that may occur. If there is a spill, immediate action should be taken to prevent the oil from entering any drains or water courses.

If absorbents are used to combat a spill, they may well be classified as hazardous waste and should be treated as such.

Appendix A - Electrical Drawings

Appendix B - Electrical Datasheets

Appendix C - Electrical Parts List

Appendix D - Mechanical Drawings
